

7.5 Amps, 600/650 Volts N-CHANNEL POWER MOSFET

DESCRIPTION

The **8N60** is a high voltage and high current power MOSFET, designed to have better characteristics, such as fast switching time, low gate charge, low on-state resistance and have a high rugged avalanche characteristics. This power MOSFET is usually used at high speed switching applications in power supplies, PWM motor controls, high efficient DC to DC converters and bridge circuits.

FEATURES

- * $R_{DS(ON)} = 1.2\Omega @ V_{GS} = 10\text{ V}$
- * Ultra low gate charge (typical 28 nC)
- * Low reverse transfer capacitance ($C_{RSS} =$ typical 12.0 pF)
- * Fast switching capability
- * Avalanche energy specified
- * Improved dv/dt capability, high ruggedness

SYMBOL

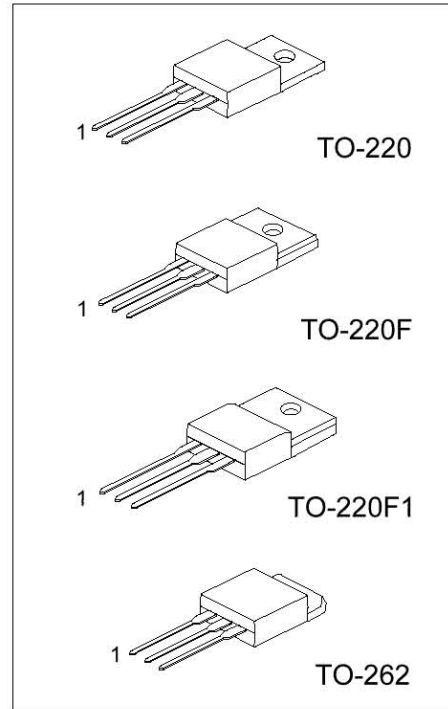
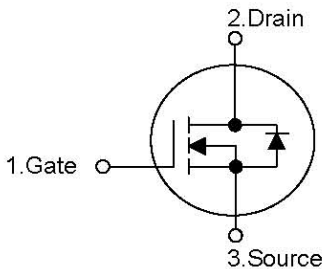

ORDERING INFORMATION

Ordering Number		Package	Pin Assignment			Packing
Lead Free	Halogen Free		1	2	3	
8N60L-x-TA3-T	8N60G-x-TA3-T	TO-220	G	D	S	Tube
8N60L-x-TF1-T	8N60G-x-TF1-T	TO-220F1	G	D	S	Tube
8N60L-x-TF3-T	8N60G-x-TF3-T	TO-220F	G	D	S	Tube
8N60L-x-T2Q-T	8N60G-x-T2Q-T	TO-262	G	D	S	Tube

Note: Pin Assignment: G: Gate D: Drain S: Source

<p>8N60L-x-TA3-T</p> <ul style="list-style-type: none"> (1)Packing Type (2)Package Type (3)Drain-Source Voltage (4)Lead Plating 	<ul style="list-style-type: none"> (1) T: Tube (2) TA3: TO-220, TF1: TO220-F1, TF3: TO-220F T2Q: TO-262 (3) A: 600V, B: 650V (4) G: Halogen Free, L: Lead Free
---	---

■ ABSOLUTE MAXIMUM RATINGS ($T_C = 25^\circ\text{C}$, unless otherwise specified)

PARAMETER		SYMBOL	RATINGS	UNIT
Drain-Source Voltage	8N60-A	V_{DSS}	600	V
	8N60-B		650	V
Gate-Source Voltage		V_{GSS}	± 30	V
Avalanche Current (Note 2)		I_{AR}	7.5	A
Drain Current	Continuous	I_D	7.5	A
	Pulsed (Note 2)	I_{DM}	30	A
Avalanche Energy	Single Pulsed (Note 3)	E_{AS}	230	mJ
	Repetitive (Note 2)	E_{AR}	14.7	mJ
Peak Diode Recovery dv/dt (Note 4)		dv/dt	4.5	V/ns
Power Dissipation	TO-220/TO-262	P_D	147	W
	TO-220F/TO-220F1		48	W
Junction Temperature		T_J	+150	$^\circ\text{C}$
Operating Temperature		T_{OPR}	-55 ~ +150	$^\circ\text{C}$
Storage Temperature		T_{STG}	-55 ~ +150	$^\circ\text{C}$

Notes: 1. Absolute maximum ratings are those values beyond which the device could be permanently damaged.

Absolute maximum ratings are stress ratings only and functional device operation is not implied.

2. Repetitive Rating : Pulse width limited by T_J
3. $L = 7.3\text{mH}$, $I_{AS} = 7.5\text{A}$, $V_{DD} = 50\text{V}$, $R_G = 25\ \Omega$, Starting $T_J = 25^\circ\text{C}$
4. $I_{SD} \leq 7.5\text{A}$, $di/dt \leq 200\text{A}/\mu\text{s}$, $V_{DD} \leq BV_{DSS}$, Starting $T_J = 25^\circ\text{C}$

■ THERMAL DATA

PARAMETER		SYMBOL	RATING	UNIT
Junction to Ambient	TO-220/TO-262	θ_{JA}	62.5	$^\circ\text{C}/\text{W}$
	TO-220F/TO-220F1		62.5	$^\circ\text{C}/\text{W}$
Junction to Case	TO-220/TO-262	θ_{JC}	0.85	$^\circ\text{C}/\text{W}$
	TO-220F/TO-220F1		2.6	$^\circ\text{C}/\text{W}$

■ ELECTRICAL CHARACTERISTICS ($T_C = 25^\circ\text{C}$, unless otherwise specified)

PARAMETER		SYMBOL	TEST CONDITIONS	MIN	TYP	MAX	UNIT
OFF CHARACTERISTICS							
Drain-Source Breakdown Voltage	8N60-A	BV_{DSS}	$V_{GS} = 0\text{V}$, $I_D = 250\ \mu\text{A}$	600			V
	8N60-B			650			V
Drain-Source Leakage Current		I_{DSS}	$V_{DS} = 600\text{V}$, $V_{GS} = 0\text{V}$			10	μA
Gate-Source Leakage Current	Forward	I_{GSS}	$V_{GS} = 30\text{V}$, $V_{DS} = 0\text{V}$			100	nA
	Reverse			$V_{GS} = -30\text{V}$, $V_{DS} = 0\text{V}$			-100
Breakdown Voltage Temperature Coefficient		$\Delta BV_{DSS}/\Delta T_J$	$I_D = 250\ \mu\text{A}$, Referenced to 25°C		0.7		$\text{V}/^\circ\text{C}$
ON CHARACTERISTICS							
Gate Threshold Voltage		$V_{GS(TH)}$	$V_{DS} = V_{GS}$, $I_D = 250\ \mu\text{A}$	2.0		4.0	V
Static Drain-Source On-State Resistance		$R_{DS(ON)}$	$V_{GS} = 10\text{V}$, $I_D = 3.75\text{A}$		1.0	1.2	Ω
DYNAMIC CHARACTERISTICS							
Input Capacitance		C_{ISS}	$V_{DS} = 25\text{V}$, $V_{GS} = 0\text{V}$, $f = 1\text{MHz}$		965	1255	pF
Output Capacitance		C_{OSS}		105	135	pF	
Reverse Transfer Capacitance		C_{RSS}		12	16	pF	
SWITCHING CHARACTERISTICS							
Turn-On Delay Time		$t_{D(ON)}$	$V_{DD} = 300\text{V}$, $I_D = 7.5\text{A}$, $R_G = 25\ \Omega$ (Note 1, 2)		16.5	45	ns
Turn-On Rise Time		t_R		60.5	130	ns	
Turn-Off Delay Time		$t_{D(OFF)}$		81	170	ns	
Turn-Off Fall Time		t_F		64.5	140	ns	
Total Gate Charge		Q_G		28	36	nC	
Gate-Source Charge		Q_{GS}	4.5		nC		
Gate-Drain Charge		Q_{GD}	12		nC		

■ ELECTRICAL CHARACTERISTICS(Cont.)

PARAMETER	SYMBOL	TEST CONDITIONS	MIN	TYP	MAX	UNIT
DRAIN-SOURCE DIODE CHARACTERISTICS AND MAXIMUM RATINGS						
Drain-Source Diode Forward Voltage	V_{SD}	$V_{GS} = 0\text{ V}, I_S = 7.5\text{ A}$			1.4	V
Maximum Continuous Drain-Source Diode Forward Current	I_S				7.5	A
Maximum Pulsed Drain-Source Diode Forward Current	I_{SM}				30	A
Reverse Recovery Time	t_{RR}	$V_{GS} = 0\text{ V}, I_S = 7.5\text{ A},$		365		ns
Reverse Recovery Charge	Q_{RR}	$dI_F/dt = 100\text{ A}/\mu\text{s}$ (Note 2)		3.4		μC

Notes: 1. Pulse Test: Pulse width $\leq 300\mu\text{s}$, Duty cycle $\leq 2\%$
 2. Essentially independent of operating temperature

■ TEST CIRCUITS AND WAVEFORMS

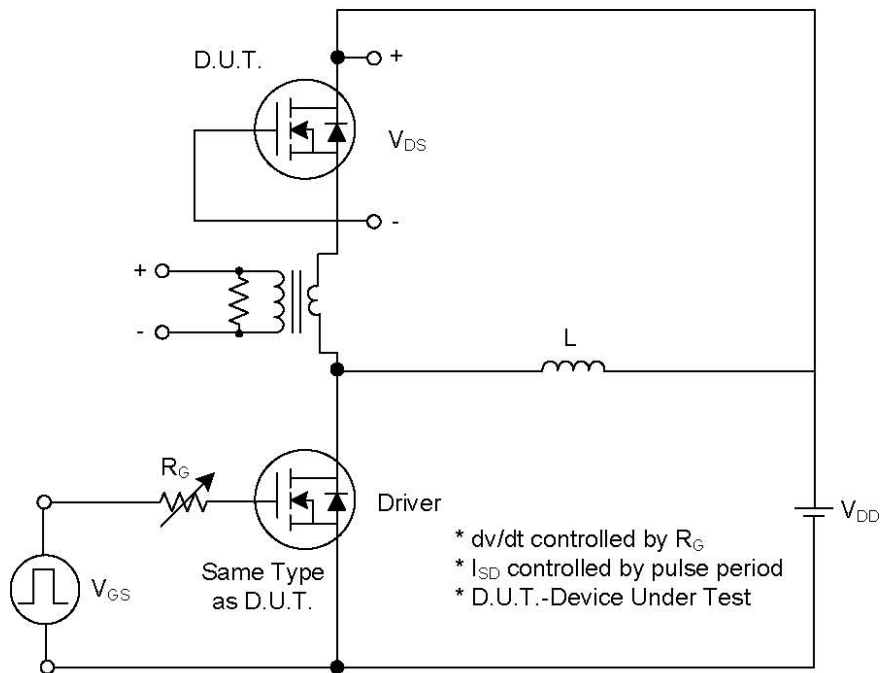

Fig. 1A Peak Diode Recovery dv/dt Test Circuit

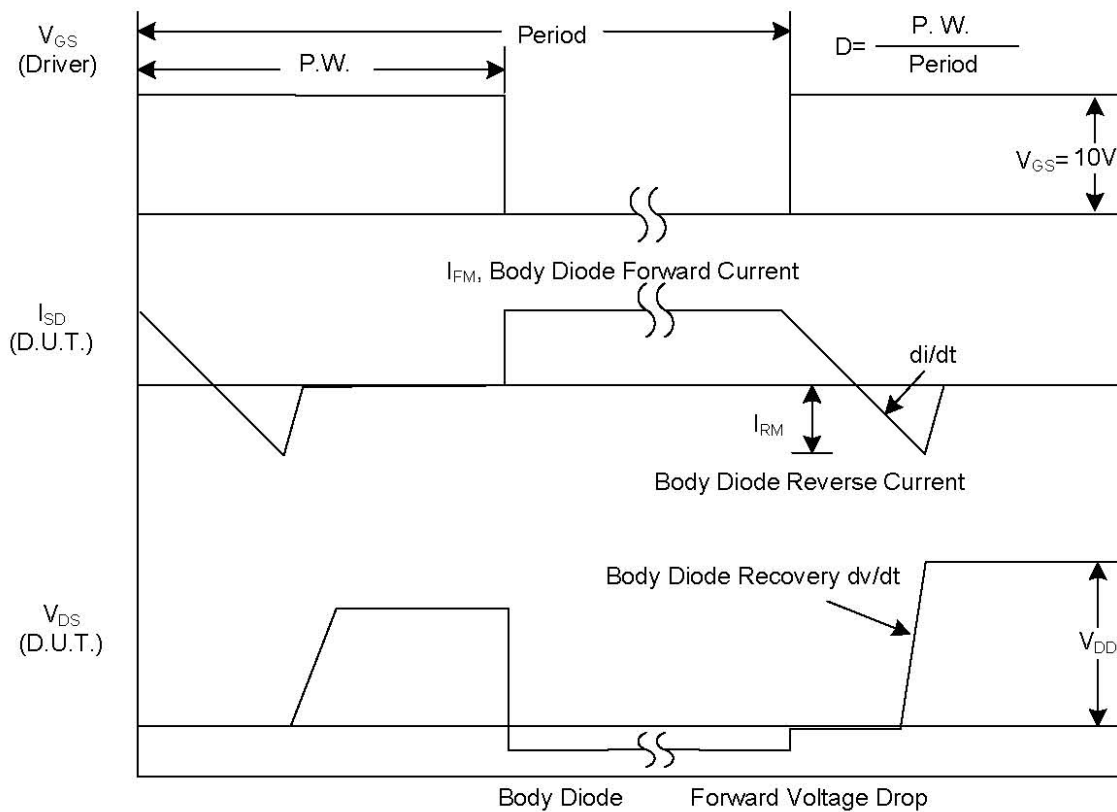

Fig. 1B Peak Diode Recovery dv/dt Waveforms

■ TEST CIRCUITS AND WAVEFORMS (Cont.)

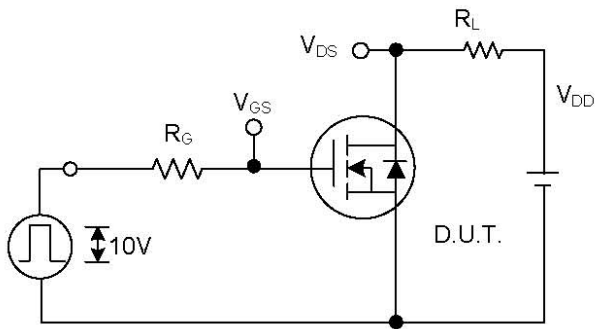

Fig. 2A Switching Test Circuit

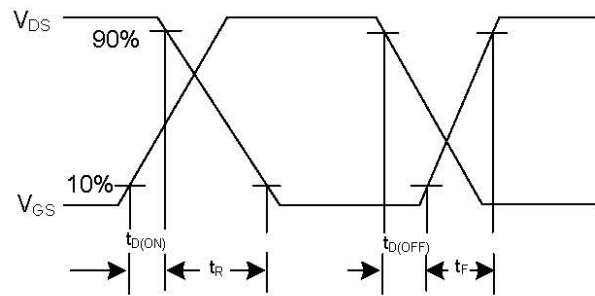

Fig. 2B Switching Waveforms

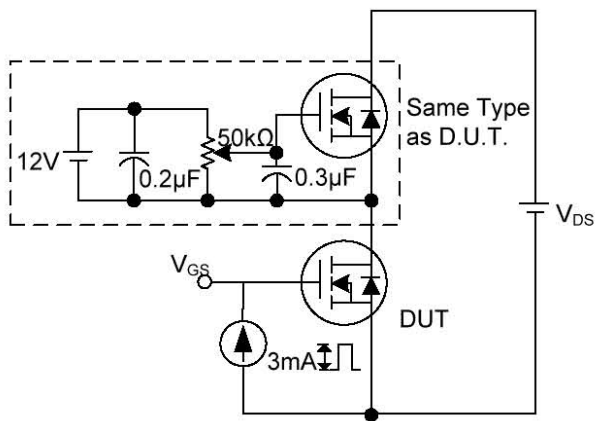

Fig. 3A Gate Charge Test Circuit

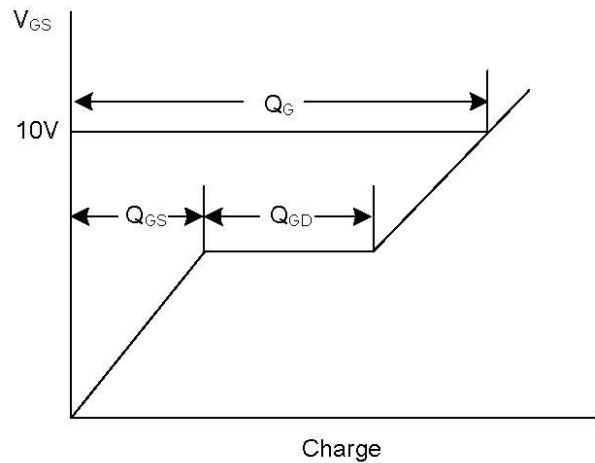

Fig. 3B Gate Charge Waveform

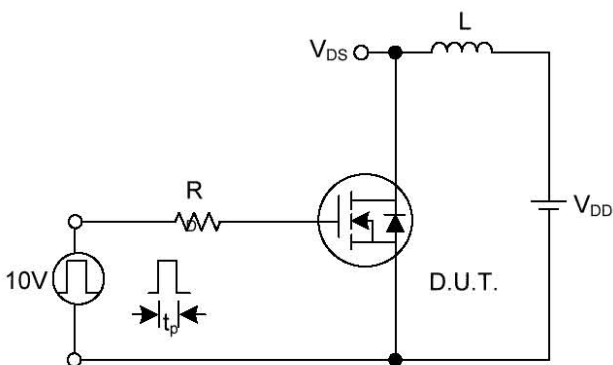

Fig. 4A Unclamped Inductive Switching Test Circuit

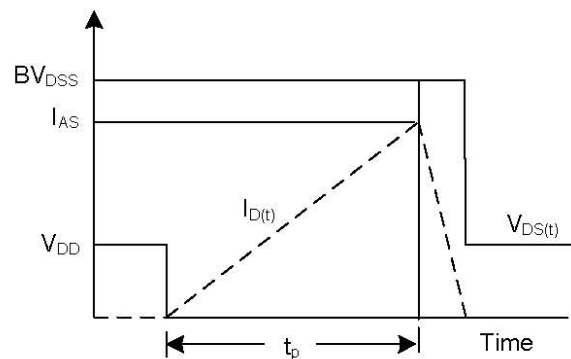
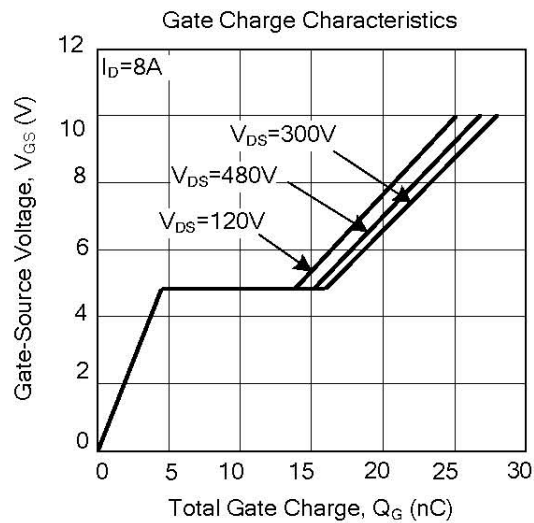
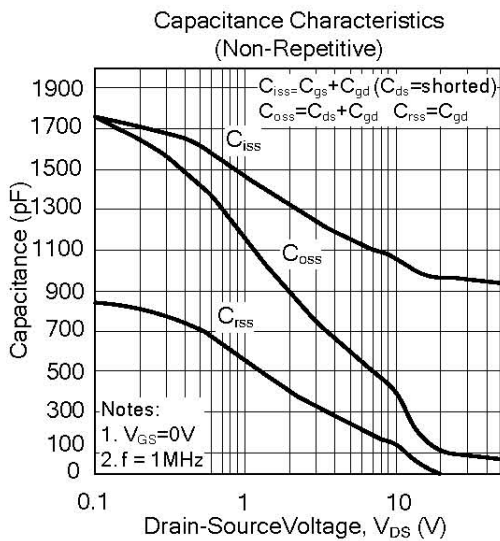
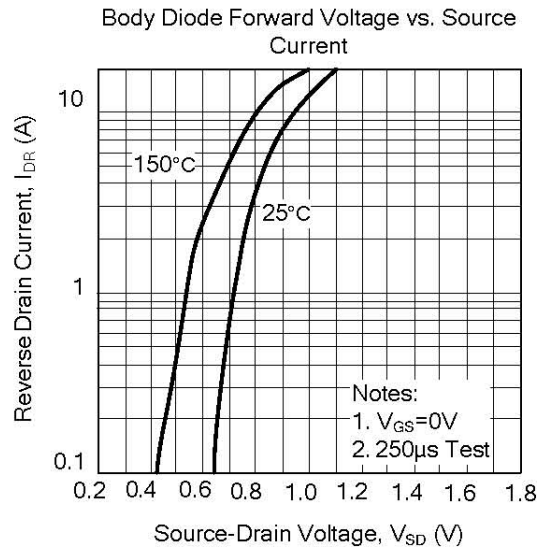
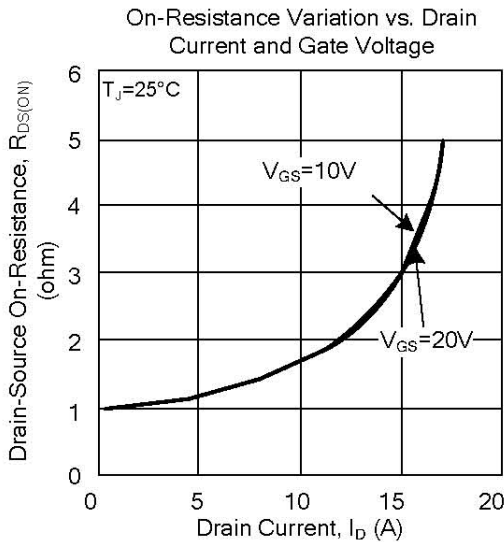
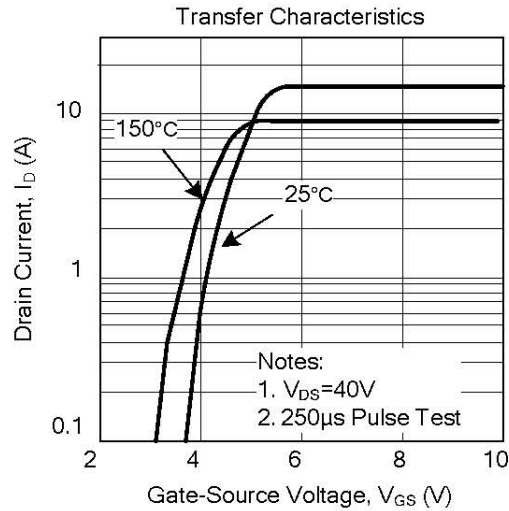
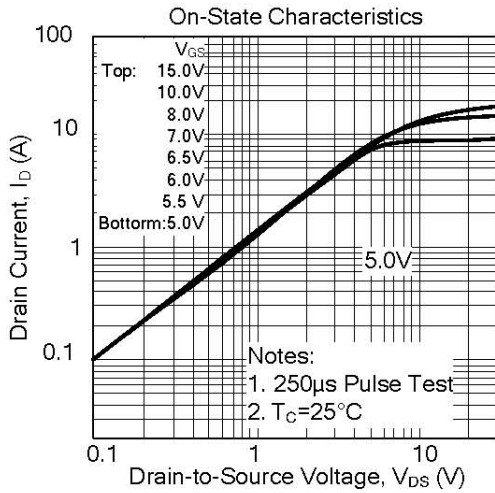

Fig. 4B Unclamped Inductive Switching Waveforms

■ **TYPICAL CHARACTERISTICS**



■ **TYPICAL CHARACTERISTICS(Cont.)**

